

VT86 Series Pressure Rating up to 413bar (6,000 psig)
VTH86 Series pressure Rating up to 689bar (10,000 psig)
VCT86 Series CNG/NGV Valves



Features

- The Trunnion ball valve is featured by blowout-proof design with cylindrical extensions at the top and bottom of the ball.
- The trunnion prevents the ball from shifting and permits the ball to rotate on a vertical axis.
- Integral ball stem machined from single piece of bar stock eliminates the backlash during handle actuation.
- Panel mounting nut is standard permitting valve to panel or actuator.

Technical Data

Valve Series	Seat Material	Temperature Rating °C (°F)	Pressure Rating at 37 °C (100°F)
VT86	PCTFE	-17 to 121 (0 to 250)	413bar (6,000psig)
	PEEK	- 17 to 232 (0 to 450)	413bar (6,000psig)
	PTFE	- 17 to 232 (0 to 450)	103bar (1,500psig)
VTH86	PEEK	-17 to 232 (0 to 450)	413 to 689bar (6,000 to 10,000psig)

Operation

- Valves that have not been actuated for a period of time may have a higher initial actuation torque.
- VT86 Series ball valves are designed to control fluid in full open and full closed position.

Factory Test

Every valve is factory tested with nitrogen gas at 68.9bar (1,000psig) for leakage to a maximum allowable leak rate of 0.1 SCCM at seat. Hydraulic shell test is optionally performed at 1.5 times the working pressure to a requirement of no detectable leakage with a liquid leak detector.

Cleaning and Packaging

Every valve is cleaned and packaged in accordance with DK-Lok cleaning standard DC-01. Special cleaning and packaging in accordance with DK-Lok standard DC-11 ensures compliance with product cleaning of ASTM G93 Level C is available on request for valves with PCTFE and PTFE seats.

CNG/NGV Certifications

VCT86 and VCT863 Series valve provides leak-tight integrity in both low and high pressure systems in CNG and NGV applications. Valves with PAI seat and HNBR O-ring are compatible with CNG fluid.

Valve Series	Certificates	ECE R110	ANSI / AGA NGV 3.1-1995 CGV NGV 12.3-M95	ANSI /IAS NGV 4.6-1999 CSA 12.56-M99	ISO 15500
VCT86 Series 2-way ball valves	Certificate No.	110R-000184	2010-REPORT-005 (00)	2010-REPORT-006 (00)	2010-REPORT-004 (00)
	Classification	Class 0	manual valve	manual valve (Class B)	manual valve
	Temperature	-40 to 120 °C (-40 to 250 °F)	-40 to 121 °C (-40 to 250 °F)	-40 to 65 °C (-40 to 150 °F)	-40 to 121 °C (-40 to 250 °F)
	Working Pressure	274 bar @ 120 °C	273 bar @ 121 °C	293 bar @ 65 °C	273 bar @ 121 °C
VCT863 Series 3-way ball valves	Certificate No.	110R-000185	2010-REPORT-011 (00)	2010-REPORT-012 (00)	2010-REPORT-010 (00)
	Classification	Class 0	manual valve	manual valve (Class B)	manual valve
	Temperature	40 to 120 °C	- 40 to 121 °C	-40 to 65 °C	- 40 to 121 °C
	Working Pressure	274 bar @ 120 °C	273 bar @ 121 °C	293bar @ 65 °C	273 bar @ 121 °C

VT86 / VCT86 Series For 2-Way

VT86 / VCT86 Series For 3-Way & VTH86 Series For 2-Way, 3-Way

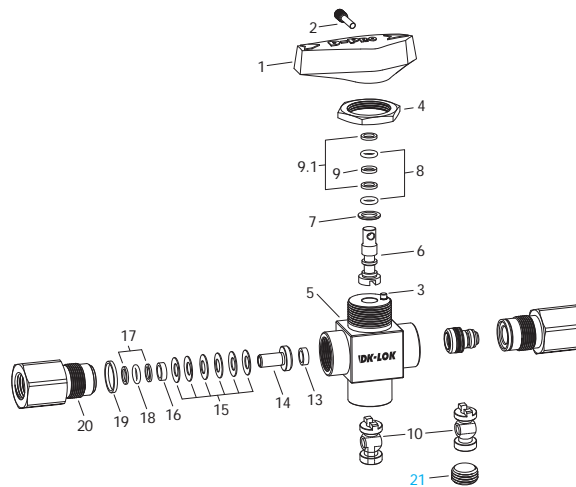
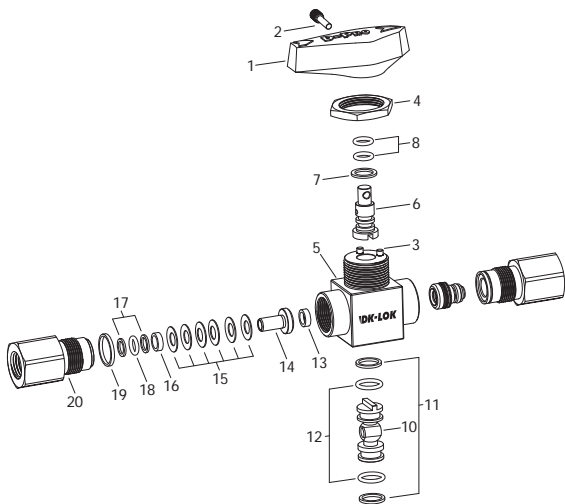

VTH86 Series For 2-Way



3-Way valve with an arrow marking on the top of 6. stem.
The arrow marking helps set a direction of the valve handle after the handle is removed from its mounting panel.

Materials of Construction

Component	VT86/VCT86 Series		VTH86 Series	
	2-Way	3-Way	2-Way	3-Way
	Grade/ASTM Specification			
1. Handle	Nylon with brass insert			
2. Set screw	SS316/A276			
3. Stop pin (2-Way - 2, 3-Way - 1)	SS316			
4. Panel nut	SS316/A479 or A276			
5. Body	SS316/A479 or A276			
6. Stem	SS316/A479 or A276			
7. Stem bearing	PEEK			
8. Stem O-rings (2)	FKM O-ring (HNBR for VCT86/VCT863 Series)		FKM O-ring	
9. Stem support ring	-	PEEK		
9.1. Stem backup rings (2)	-	PTFE/D1710, type 1		
10. Trunnion ball	SS316/A479 or A276			
11. Trunnion ball back-up rings (2)	Reinforced PTFE		-	
12. Trunnion ball O-rings (2)	FKM O-ring (HNBR for VCT86 Series)		-	
13. Seats (2)	PCTFE, optional PTFE, PEEK (PAI for VCT86/VCT863 Series)		PEEK	
14. Seat carriers (2)	SS316/A479 or A276			
15. Seat springs (12)	Alloy X-750/AMS 5542			
16. Seat carrier guides (2)	SS316/A479 or A276			
17. Seat carrier back-up rings (4)	Reinforced PTFE			
18. Seat carrier O-rings (2)	FKM O-ring (HNBR for VCT86/VCT863 Series)		FKM O-ring	
19. End connector seals (2)	PTFE/D1710,type 1			
20. End connectors (2)	SS316/A479 or A276			
21. Plug	-	-	SS316/A479 or A276	-

- Wetted components and lubricants are listed in **BLUE**.
- **Lubricants** : Molybdenum disulfide and fluorinated based.

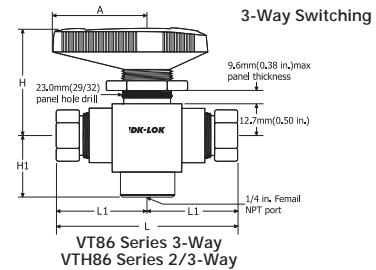
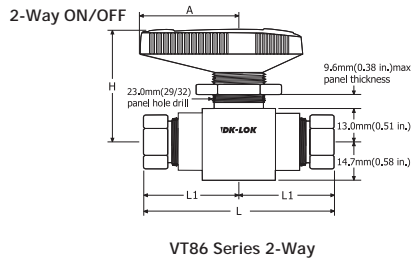

Ordering Information and Dimensions

VT86 Series Basic Ordering Number	Cv	Orifice mm (in.)	VTH86 Series Basic Ordering Number	Cv	Orifice mm (in.)	End Connection	Dimensions, mm (in.)				
							L	L1	H	A	
2-Way			2-Way								
VT86- VCT86-	F2N-	1.2	VTH86-	F2N-	1.2	1/8 in. Female NPT	76.2(3)	3.81(1.5)	46.7 (1.83)	38.0 (1.50)	
	F4N-	1		-	1	1/4 in. Female NPT					
	-	-		F4N-	1	1/4 in. Female NPT	98.5(3.88)	49.3(1.94)			
	F8N-	1.2		-	-	1/2 in. Female NPT	81.2(3.2)	40.6(1.6)			
	D4T-	1.6		D4T-	1.6	1/4 in. DK-Lok	105 (4.14)	52.6 (2.07)			
	D6T-	1.4		D6T-	1.4	3/8 in. DK-Lok	112 (4.39)	55.6 (2.19)			
	D8T-	1		D8T-	1	1/2 in. DK-Lok	117 (4.60)	58.4 (2.30)			
	D6M-	1.6		D6M-	1.6	6mm DK-Lok	105 (4.14)	52.6 (2.07)			
	D8M-	1.5		D8M-	1.5	8mm DK-Lok	105 (4.14)	52.6 (2.07)			
	D10M-	1.3		D10M-	1.3	10mm DK-Lok	112 (4.41)	55.9 (2.20)			
D12M-	1	D12M-	1	12mm DK-Lok	117(4.6)	58.4(2.3)					
3-Way			3-Way								
VT863- VCT863-	F2N-	0.75	4.75 (0.187)	VTH863-	0.75	4.75 (0.187)	1/8 in. Female NPT	76.2(3)	3.81(1.5)	46.7 (1.83)	38.0 (1.50)
	F4N-						1/4 in. Female NPT	76.2(3)	38.1(1.5)		
	-						1/4 in. Female NPT	81.2(3.2)	40.6(1.6)		
	D4T-						1/4 in. DK-Lok	105 (4.14)	52.6 (2.07)		
	D6T-						3/8 in. DK-Lok	112 (4.39)	55.6 (2.19)		
	D8T-						1/2 in. DK-Lok	117 (4.60)	58.4 (2.30)		
	D6M-						6mm DK-Lok	105 (4.14)	52.6 (2.07)		
	D8M-						8mm DK-Lok	105 (4.14)	52.6 (2.07)		
	D10M-						10mm DK-Lok	112 (4.41)	55.9 (2.20)		
	D12M-						12mm DK-Lok	117(4.6)	58.4(2.3)		

All dimensions shown are for reference only and are subject to change. Dimension with DK-Lok nuts are in finger-tight position.

* **CNG/NGV valve ordering number** : Basic ordering numbers listed in blue are for CNG/NGV valves as well.

Flow Rate

VT86 series Flow Data @ 21 °C (70 °F)

Flow Rate	Pressure Drop to Atmosphere (ΔP) in bar (psig)	3-Way		2-Way				
		Cv 0.75	Cv 1	Cv 1.2	Cv 1.3	Cv 1.4	Cv 1.5	Cv 1.6
Water	0.68 (10)	9.0(2.4)	12.1 (3.2)	14.3 (3.8)	15.5 (4.1)	17.8 (4.4)	17.8 (4.7)	19.3 (5.1)
L/min	3.4 (50)	20.0 (5.3)	26.8 (7.1)	32.1 (8.5)	34.8 (9.2)	37.4 (9.9)	40.1 (10.6)	42.7 (11.3)
(U.S.GPM)	6.8 (100)	28.3 (7.5)	37.8 (10.0)	45.4 (12.0)	49.2 (13.0)	53.0 (14.0)	56.7 (15.0)	60.5 (16.0)
Air	0.68 (10)	226 (8.0)	311 (11.0)	396 (14.0)	424 (15.0)	453 (16.0)	481 (17.0)	509 (18.0)
std L/min	3.4 (50)	651 (23.0)	849 (30.0)	1019 (36.0)	1104 (39.0)	1189 (42.0)	1274 (45.0)	1359 (48.0)
(SCFM)	6.8 (100)	1132 (40.0)	1500 (53.0)	1812 (64.0)	1953 (69.0)	2095 (74.0)	2265 (80.0)	2406 (85.0)

VTH86 series Flow Data @21 °C (70°F)

Flow Rate	Pressure Drop to Atmosphere (ΔP) in bar (psig)	3-Way		2-Way				
		Cv 0.75	Cv 1	Cv 1.2	Cv 1.3	Cv 1.4	Cv 1.5	Cv 1.6
Water	10.3 (150)	34.8 (9.2)	45.4 (12)	56.7 (15)	60.5 (16)	64.3 (17)	68.1 (18)	74.1 (19.6)
L/min	41.3 (600)	69.1 (18)	94 (25)	109 (29)	121 (32)	128 (34)	140 (37)	147 (39)
(U.S.GPM)	68.9 (1000)	90.8 (24)	143 (38)	143 (38)	155 (41)	166 (44)	178 (47)	189 (50)
Air	10.3 (150)	1614 (57)	2152 (76)	2805 (92)	2803 (99)	3029 (107)	3256 (115)	3454 (122)
std L/min	41.3 (600)	5946 (210)	8070 (285)	9627 (340)	10 505 (371)	11 298 (399)	12 119 (428)	12 912 (456)
(SCFM)	68.9 (1000)	9912 (350)	13 308(470)	16 140 (570)	17 272 (610)	18 688 (660)	19 821 (700)	21 321 (750)

VT86 Series Pressure-Temperature Ratings

Body material		316 Stainless steel					
Seat material		PTCFE		PTFE		PEEK	
Temperature		bar	psig	bar	psig	bar	psig
°C	°F	Working Pressure					
-17 to 37	0 to 100	413	6000	103	1500	413	6000
65	150	206	3000	77.5	1125	399	5800
93	200	137	2000	51.6	750	344	5000
121	250	69	1000	43	625	282	4100
148	300	-	-	34.4	500	220	3200
176	350	-	-	25.8	375	158	2300
204	400	-	-	17.2	250	96.4	1400
232	450	-	-	8.6	125	34.4	500

VTH86 Series Pressure-Temperature Ratings

Body material		316 Stainless steel							
End Connection	DK-Lok	6M, 1/4 in.	8M, 3/8 in.	12M, 1/2 in.	10M				
	Female NPT	1/8, 1/4 in.	-	-	-				
Seat Material		PEEK							
Temperature		Working Pressure							
°C	°F	bar	psig	bar	psig	bar	psig	bar	psig
-17 to 37	0 to 100	689	10000	516	7500	454	6600	413	6000
65	150	516	7500	516	7500	454	6600	406	5900
93	200	344	5000	344	5000	344	5000	344	5000
121	250	282	4100	282	4100	282	4100	282	4100
148	300	220	3200	220	3200	220	3200	220	3200
176	350	158	2300	158	2300	158	2300	158	2300
204	400	96.4	1400	96.4	1400	96.4	1400	96.4	1400
232	450	34.4	500	34.4	500	34.4	500	34.4	500

Options

VT86 Series 2-Way Valve External Vent Options

A downstream or upstream vent option on VT86 Series 2-Way ball valve is available. The vent port is constructed on trunnion ball. The vent port activates when the valve is in closed position. This option reduces the valve pressure rating to 34.4bar (500 psig).

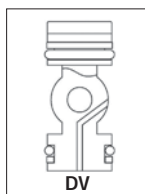

Downstream Vent
Ordering designator - DV

When a downstream vent valve in closed position, shutoff at the upstream seat occurs. Downstream system media flows into the vent hole and vents out to atmosphere through the valve bottom.

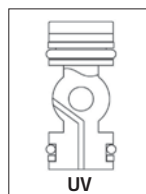

Upstream Vent
Ordering designator - UV

When an upstream vent valve in closed position, shutoff at the downstream seat occurs. Upstream system media flows into the vent hole and vents out to atmosphere through the valve bottom.

Service Kit

For field assembly, service kit with a maintenance instruction is available. Service kit contains wetted parts including trunnion ball, stem assembly and seat carrier assembly. To order the service kit, prefix SK- to the valve series. i.e., SK-VCT863, SK-VTH863.

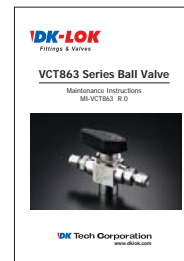

How to Order

Select applicable valve basic ordering number, options and body material designator listed below.

VT86-D4T VTH86-D12M VCT86-F4N	-PK ↓	-DV ↓	-S -S -S ↓
Seat Materials	O-ring Materials	External Vent Options	Body Material
Nil : Standard PCTFE for VT86 Series Nil : Standard PEEK for VTH86 Series Nil : Standard PAI for VCT86 Series PC : PCTFE PK : PEEK PE : PTFE PI : PAI	Nil : Standard FKM for VT86 and VTH86 Series Nil : Standard HNBR for VCT86 Series Note : Optional O-rings applicable to; 8. Stem O-rings 12. Trunnion ball O-rings 18. Seat carrier O-rings	DV : Downstream Vent UV : Upstream Vent Note : Vent option available on VT86 2-Way ball valves.	S : Stainless steel 316

Safe Valve Selection

The selection of a valve for any application or system design must be considered to ensure safe performance. Valve function, valve rating, material compatibility, proper installation, operation and maintenance remain the sole responsibility of the system designer and the user. DK-Lok accepts no liability for any improper selection, installation, operation or maintenance.

 www.dklok.com	DK-LOK Corporation Mailing Address 7, Golden root-ro 129beon-gil, Juchon-myeon, Gimhae-si, Gyeongsangnam-do, South Korea 621-842	DK-Lok contact information Tel. (82) 55-338-0114 Fax. (82) 55-901-0143 E-mail : sales@dklok.com	For International customers Tel. (82) 55-338-0031/2 Fax. (82) 55-901-0142 E-mail : dklok@dklok.com
-------------------	---	--	---